



**MASINDE MULIRO UNIVERSITY OF
SCIENCE AND TECHNOLOGY
(MMUST)**

MAIN CAMPUS

**UNIVERSITY EXAMINATIONS
2021/2022 ACADEMIC YEAR**

THIRD YEAR SECOND SEMESTER EXAMINATIONS

**FOR THE DEGREE
OF
BACHELOR OF TECHNOLOGY
IN
BUILDING CONSTRUCTION**

COURSE CODE: BTB 314

**COURSE TITLE: CONSTRUCTION AND ENGINEERING
MATERIALS II**

DATE: MONDAY 25TH APRIL 2022 TIME: 3:00 – 5:00 PM

INSTRUCTIONS:

1. This paper contains **FIVE** questions
2. Answer **ONE** and any other **THREE** questions
3. Marks for each question are indicated in the parenthesis.
4. No unauthorized materials are allowed in the examination room
5. Examination duration is **2 Hours**

MMUT observes **ZERO** tolerance to examination cheating

This Paper Consists of 6 Printed Pages. Please Turn Over.

QUESTION 1

- a) Discuss how Water-Cement Ratio affects concrete mix. (4.5 marks)
- b) Describe the heat of hydration against time. (4 marks)
- c) Describe the dry process of cement manufacture. (9 marks)

QUESTION 2

- a) List the classification of aggregates. (3 marks)
- b) Discuss the setting time required in the process of mixing; transporting, placing and compaction concrete using Ordinary Portland Cement. (3.5 marks)
- c) Outline the factors that affect concrete shrinkage. (5 marks)
- d) Define creep and state the effects of Creep on mass concrete and reinforced concrete. (6 marks)

QUESTION 3

Design a mix with a mean 28 days compressive strength (measured on standard cubes) of 40 MPa with a 8% standard deviation and 10% defective rate ($k = 1.28$); slump of 125 mm; crushed aggregates with a maximum size of 10 mm; specific gravity of aggregates of 2.65; 60 per cent of fine aggregates passes the 600 μm sieve; no air entrainment required; ordinary Portland cement to be used. (17.5 mark)

QUESTION 4

Explain the occurrence of the different cracks shown in Figure 4 (17.5 marks)

QUESTION 5

- a) List the conditions that courses of Delayed Ettringite Formation in Cement. (2.5 marks)
- b) Describe Thaumasite attack on concrete. (5 marks)
- c) Describe Chloride attack on concrete structure. (5 marks)
- d) Describe how to conduct a Carbonation test on concrete specimens to be tested. (5 mark)

QUESTION 6

- a) List ways Fly ash can modify the fresh concrete properties? (7 marks)
- b) Explain the benefits of Micro Silica in concrete. (3.5 marks)
- c) Discuss the four methods of processing molten slag. (4 marks)
- d) Describe fibres advantages over reinforcement bar in concrete. (3 marks)

Type of cement	Type of coarse aggregate	Compressive strengths (N/mm ²)			
		Age (days)			
		3	7	28	91
Ordinary Portland (OPC) or sulphate-resisting Portland (SRPC)	Uncrushed	22	30	42	49
	Crushed	27	36	49	56
Rapid-hardening Portland (RHPC)	Uncrushed	29	37	48	54
	Crushed	34	43	55	61

1 N/mm² = 1 MN/m² = 1 MPa (see footnote on earlier page).

Table 1. Approximate compressive strength (N/mm²) of concrete mixes made with a free-water/cement ratio of 0.5

Slump (mm)		0-10	10-30	30-60	60-180
Vebe time(s)		> 12	6-12	3-6	0-3
Maximum size aggregate (mm)	Type of aggregate				
10	Uncrushed	150	180	205	225
	Crushed	180	205	230	250
20	Uncrushed	135	160	180	195
	Crushed	170	190	210	225
40	Uncrushed	115	140	160	175
	Crushed	155	175	190	205

Table 2. Approximate free-water contents (kg/m³) required to give various levels of workability

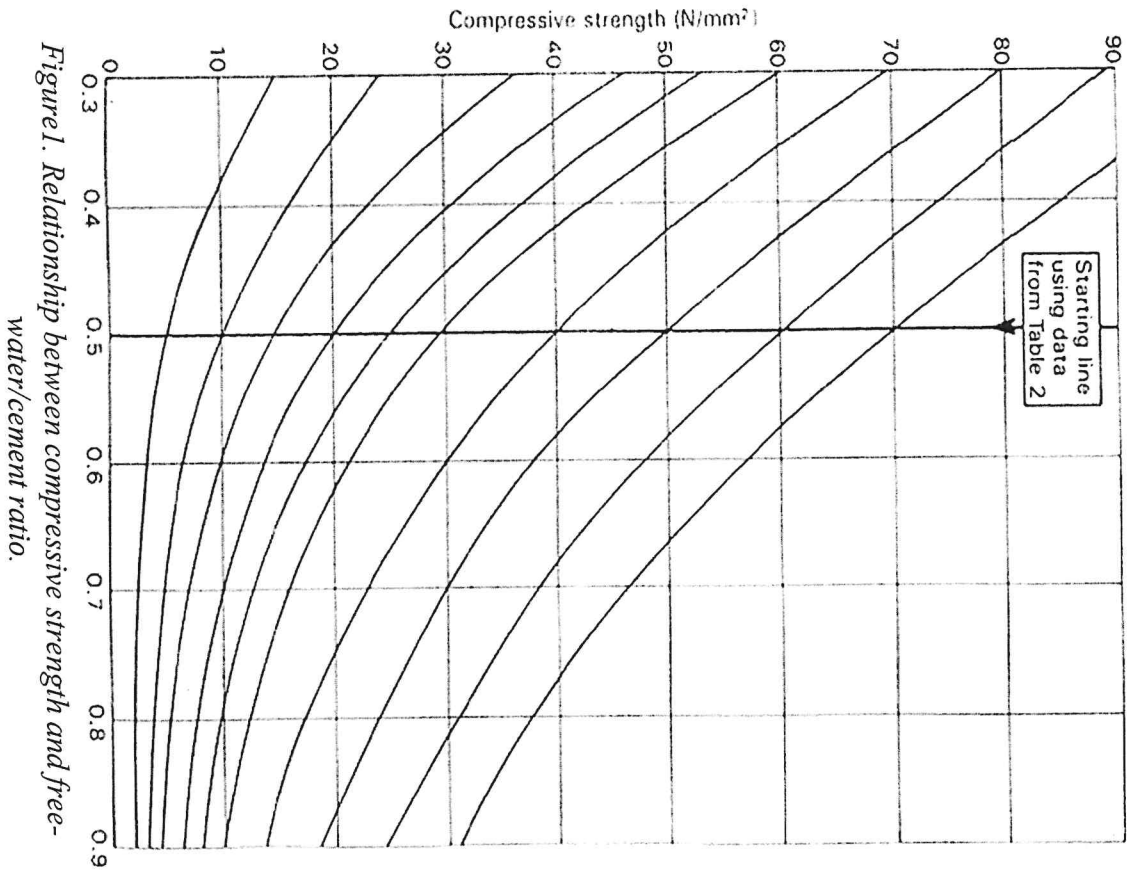

Figure 1. Relationship between compressive strength and free-water/cement ratio.

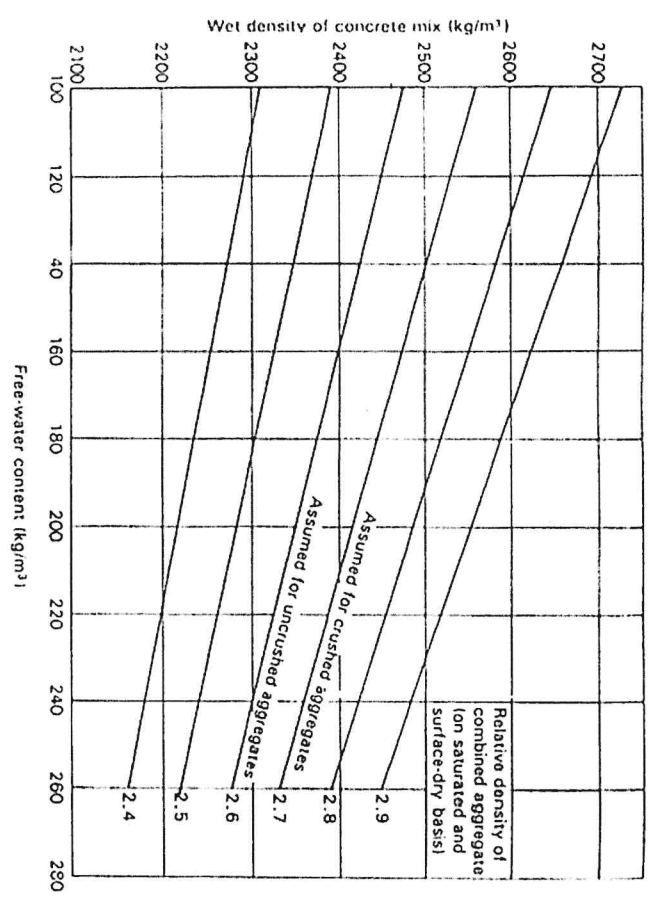

Figure 2. Estimated wet density of fully compacted concrete

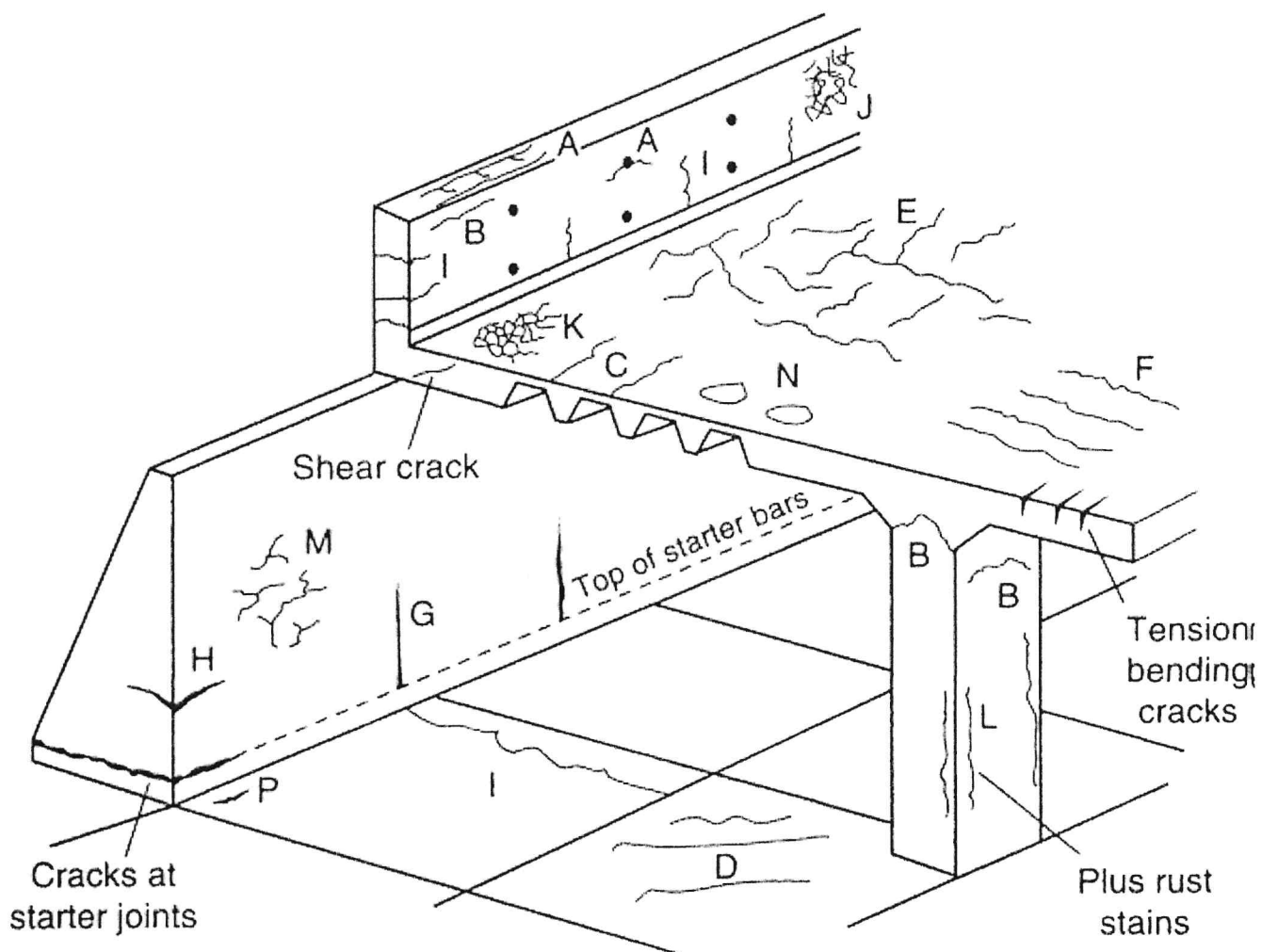

Figure 4 Schematic representations of the various types of cracking which can occur in concrete

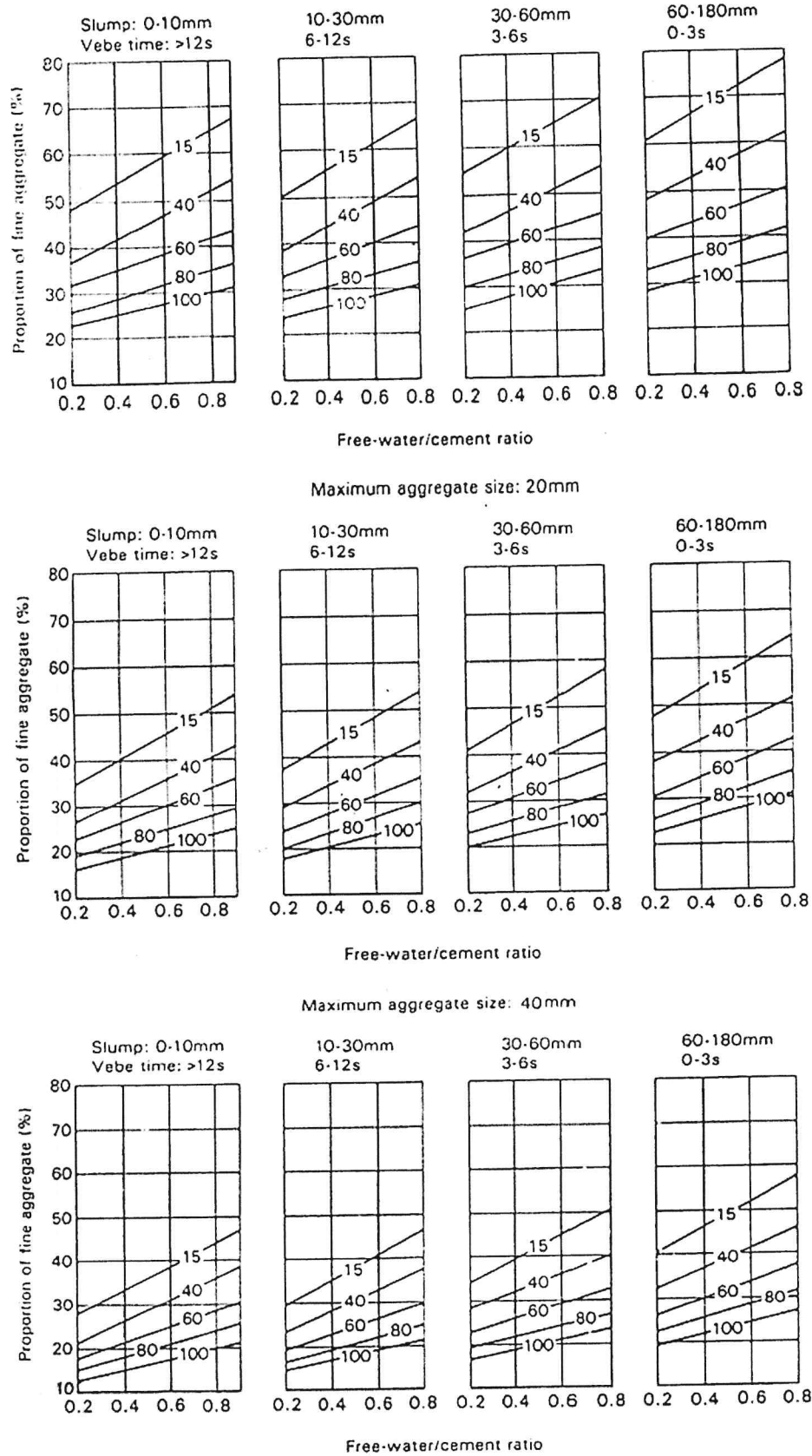

Figure 3. Recommended proportions of fine aggregate according to percentage passing a 600 μm sieve